

FOREST SERVICE AND WILDFIRE EMERGENCY RESPONSE RESOURCES FOR TRUCKS AND EQUIPMENT

MANAGING EQUIPMENT TROUBLE IN LIFE AND DEATH SCENARIOS

BY PILLAR CREEK EQUIPMENT LLC



COPYRIGHT BEN L. EVRIDGE 2025

TABLE OF CONTENTS

P2-TRAINING & TECHNICAL SUPPORT RESOURCES

P3-INTRODUCTION

P4-TIPS FOR MOST TYPES OF MACHINES

P5-INTRODUCING BEN L EVRIDGE

P6-NO.1 FLAT TIRES AND MISSING WHEELS

P8-NO.2 PUNCTURED TRANSMISSION OIL PAN

P10-NO.3 FUEL AND OIL LEAKS

P12-NO.4 RUNNING OUT OF DIESEL FUEL

P14-NO.5 BREAKING YOUR LAST SAWZALL BLADE

P16-NO.6 CUTTING A LARGER DIAMETER HOLE

P18-NO.7-RUNNING OUT OF STARTING FLUID

P20-NO.8 STARTING ENGINE WITH DEAD BATTERY

P22-NO.9 A QUICK ENGINE QUALITY CHECK

P24-NO.10 A PLUGGED CUTTING TORCH

P26-NO.11 WELDING ELECTRODES AVAILABLE

P28-NO.12 NO WELDING POWER SOURCE

P30-NO.13 STRIPPED CAMSHAFT COG BELT

P32-NO.14 FLAT TIRE/NO AIR COMPRESSOR

Training & Technical Support Resources

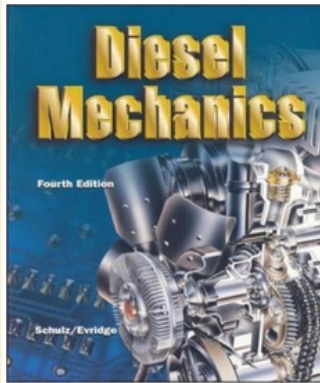

Diesel Mechanics is a training textbook sold worldwide. It presents the basics of how the most common diesel engines are constructed, tuned, and serviced. **Click image to order book.**

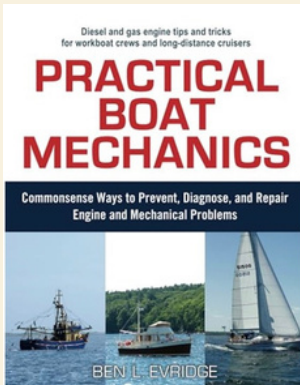

Practical Boat Mechanics covers the basics of boat repair, including how marine systems work. Included are several chapters that present how to troubleshoot by the five senses, for beginners. **Click image to order book.**



Get Home From Anywhere is a collection of techniques learned from 55 years as a HD mechanic and welder. Includes hundreds of one-page graphic summaries. **Email us to order your copy.**

INTRODUCTION

For thirty years, I worked in remote areas of Alaska performing heavy equipment repair. Often, what would normally be a one-day job would take a week, due to the huge distances involved and foul weather hindering transportation.

My customers were construction companies, gold miners, and commercial fishers. At times, the expense of getting to these jobs equaled the cost of the repair. I traveled by small plane, helicopter, skiff, and snow machine. Sometimes, I hiked in with tools and supplies.

I began collecting and illustrating self-contained heavy equipment emergency repair techniques for presentation to my class in Diesel Repair at Kodiak College. For twenty years, I taught Coast Guard members, Fish and Game biologists, psychologists, commercial pilots, fishermen, ranchers, dentists, and doctors.

During class, I would hand out the latest graphical repair tip and a hush would fall over the room. This was followed by enthusiastic discussions which invariably turned to stories of how to “save our bacon.”

I encourage people to think of the following emergency techniques as they would the Jaws of Life, that are used to free folks from crushed cars. It's not something for a sunny day, but rather for emergency situations. My material is quite a bit like the Jaws of Life, but instead of lugging a sixty pound piece of equipment with you to rescue people, this course and your own creative mindset will arm you with much more powerful problem-solving resourcefulness.

WE HAVE SOLUTIONS FOR MACHINES LIKE THESE:

FIRE TRUCKS

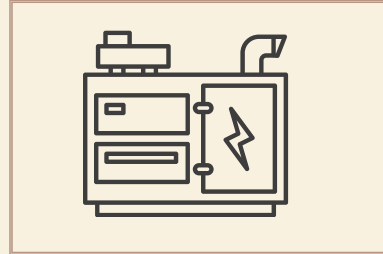
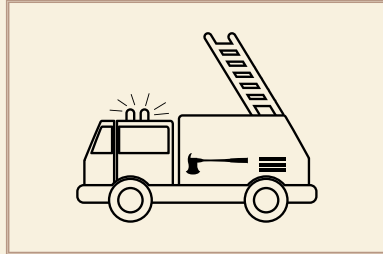

GENERATOR SETS

AMBULANCES

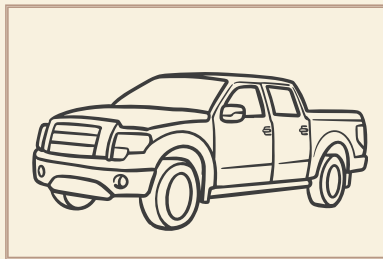
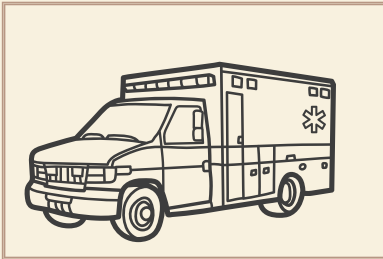

TRUCKS

FORKLIFTS

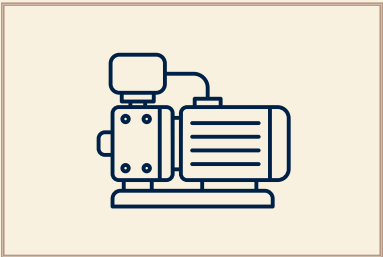
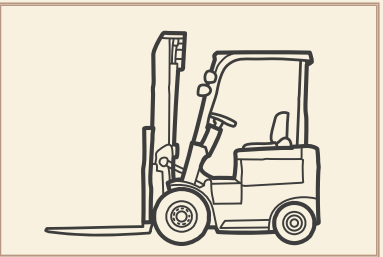

WATER PUMPS

CHAINSaws

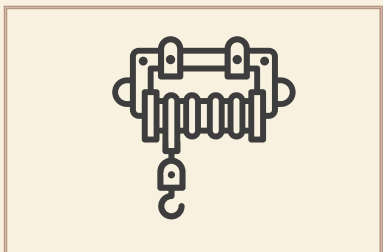
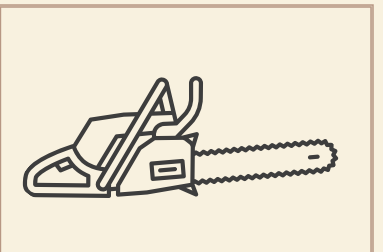

CABLE WINCHES

EARTH MOVERS

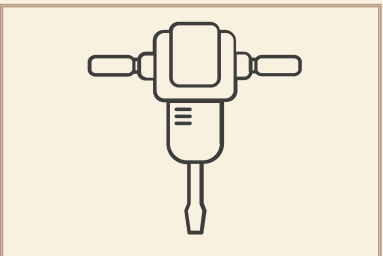
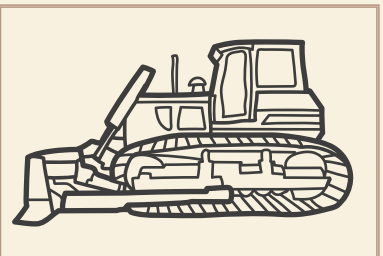

AND MANY MORE

INTRODUCING BEN L. EVRIDGE



55+ year career includes:

- Overcoming learning disabilities
- Two years of automotive and diesel training
- Two years at a Caterpillar Apprenticeship
- Fly-in bush repair of heavy equipment and fishing boats
- Twenty years as adjunct instructor of Diesel Engines at Kodiak College
- Co-author of textbook *Diesel Mechanics*
- Author of *Practical Boat Mechanics* and *Get Home From Anywhere*

.....

Let's now look at fourteen challenging scenarios, many of which are the results of civilian equipment repair. We will discuss possible solutions to each of the challenges and then demonstrate their utility on a variety of equipment.

1 - FLAT TIRES AND MISSING WHEELS



One hour after a severe earthquake...

An older woman is trapped under a fallen telephone pole. The pole is teetering and likely to fall, if not lifted carefully from a precise angle. You have cribbed and stabilized the fallen pole as much as possible with the materials at hand.

Scouring the area, you find a forklift. The engine starts, but the right rear tire on the steering axle is flat. No spare tire is available. Surrounding the machine is rubble and debris 6–12 inches deep.

Climbing into the driver's seat, you find that the machine will move. However, it is very hard to control due to the flat tire. No compressed air is available to inflate the tire.

How to proceed ?

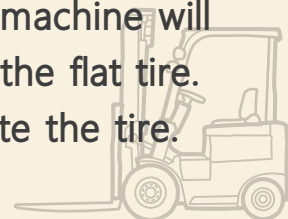

SOLUTION

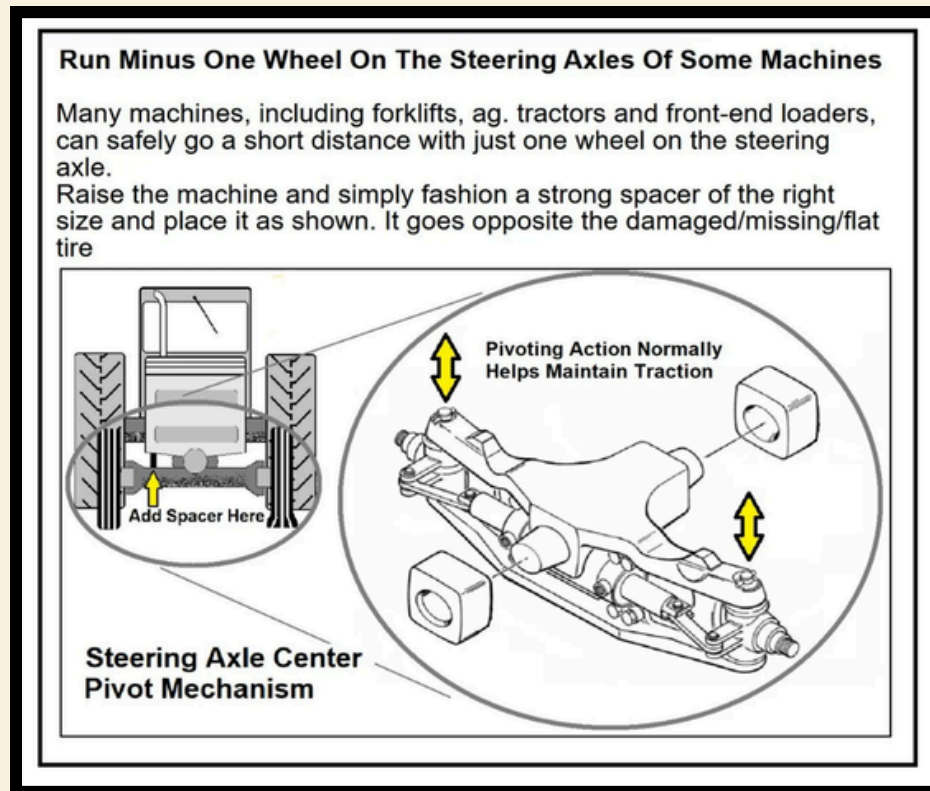

When lifting equipment is not available to jack up the machine, you can often use the machine's own hydraulic system if the machine is a forklift or front-end loader.

Find a nearby immovable object and lift against it until the steering axle is raised enough to enable insertion of the spacer block, as shown in the drawing.

2 - PUNCTURED TRANSMISSION OIL PAN



One hour after a severe earthquake, an otherwise sound and useful diesel-powered dump truck has lost its automatic transmission fluid after the transmission oil pan was punctured during the quake.

Again, we have a dire, time sensitive scenario where there is limited time to use the dump truck to transport vital supplies to first responders.

The truck starts and runs well. The engine oil pressure is good and the hole in the oil pan has been temporarily plugged. However, there is no automatic transmission fluid available to refill the transmission.

How to proceed ?



SOLUTION

Alternative Hydraulic Transmission Fluid

Montana logger Paul Gardner temporarily used diesel fuel as ATF to get home after the transmission pan was punctured, once he had plugged the leak. After getting home, he drained the fuel and refilled with ATF.

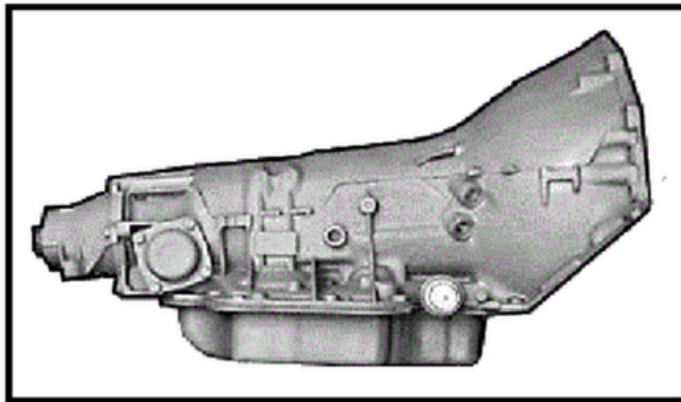

Note: Caterpillar used diesel fuel as torque converter fluid in some older D-8s and D-9s. This was discontinued because the systems were prone to leaks.

3 - FUEL AND OIL LEAKS



We will now step back in time to November of 1950 and the Battle of Chosin Reservoir, in Korea.

Vital Jeeps and trucks had their fuel systems damaged by small arms fire, with Communist Chinese troops firing at the vehicles to disable them by damaging their fuel tanks.

These vehicles were needed for the strategic retreat to the evacuation site, where the badly outnumbered troops could be taken to safety. The damaged fuel tanks and associated fuel lines running to the vehicle engines needed to be repaired quickly.

How to proceed ?

SOLUTION

Temporarily Patch Leaking Plumbing With A Tootsie Roll, Or Epoxy Stick

For more on this, search the Battle of Chosin Reservoir

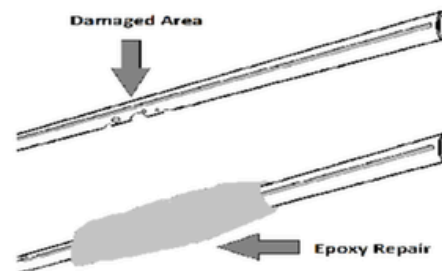

This technique does work with Tootsie Rolls in a cold climate on fuel or air lines. It works even better with modern epoxy stick, in any climate, on low pressure coolant, water, fuel and air lines.

Here are detailed instructions for a successful outcome:

Drain the piece to be repaired. If it contains fluid, dry it thoroughly.

Remove any dirt or paint from the exterior surface.

If it is a metal tube, sand or scuff the exterior slightly.

If possible, warm the piece to be repaired.

Follow the directions on the epoxy stick, mixing the two parts thoroughly, while wearing plastic gloves on your hands.

Form a sheet of the uncured epoxy and wrap it around the site of the damage.

Don't squeeze it into holes in the work piece because it can block the flow inside of the tube being repaired. Rather, let it cure before taping its exterior.

Put a test piece on a nearby area, so you can continually check the state of cure and hardness. When it gets fairly firm, it's OK to wrap, and be sure to wrap the tube or hose well past the damaged area.

In the case of fuel tanks with bullet holes in them, even while the fuel is running out, it is possible to push a Tootsie Roll or piece of caramel candy in the opening and stop the leak. Candy carried in your pocket will stay warm and soft, but will quickly harden in the cold.

4 - RUNNING OUT OF DIESEL FUEL



A few years after the Korean war, in peaceful South Dakota, a diesel-powered logging truck ran out of fuel five miles from home.

The Danne brothers had no extra fuel with them, and there was no other traffic on the road at that time of night.

It was important that they got the truck going and got home in time to refuel the truck and get a couple of hours of sleep before the next day's work.

How to proceed? The following details of the solution will surprise you.

SOLUTION

ONE OF THE BROTHERS PROPOSED, "SINCE OIL FLOATS ON WATER, LET'S POUR OUR REMAINING WATER IN THE FUEL TANK AND SEE IF IT LIFTS THE SMALL AMOUNT OF FUEL IN THE TANK UP TO THE PICK-UP TUBE." THE ENGINE STARTED AND A SHORT TIME LATER THEY ARRIVED HOME.

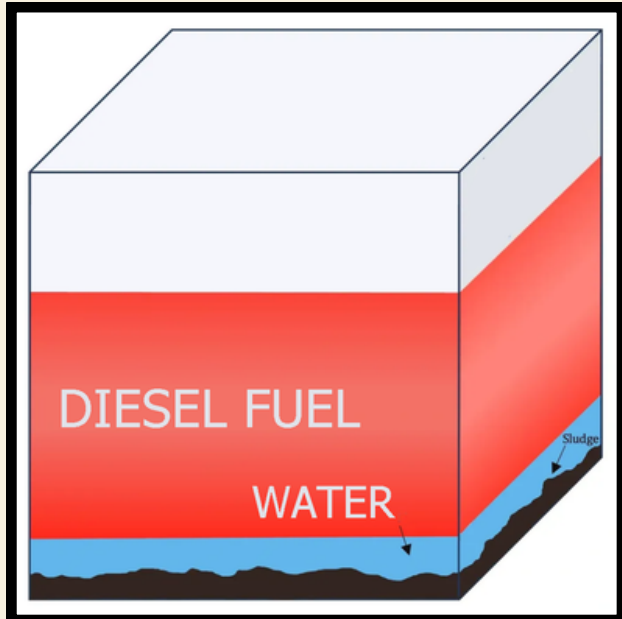

In past years, adding oil to an engine during the Indy 500 race was prohibited.

However, some racers, such as Andy Granatelli added water to the engine crankcase as the oil level got low. They knew that engine oil would float on top of the water, allowing it to be picked up by the oil pump for some lubrication. This sometimes worked, enabling them to complete a race.

5 - YOUR LAST SAW BLADE BREAKS



A tsunami just struck. You are cutting through a small I-beam that has fallen, obstructing an opening under a collapsed building, through which injured folks must be evacuated.

With one inch of material remaining to be cut, your last reciprocating (Sawzall) blade breaks, at the end where it attaches to the saw.

While the available tools at the site are very limited, you do have a battery powered reciprocating saw, a drill motor and just a few small drill bits. Nothing else is available to help you.

How to proceed ?

SOLUTION

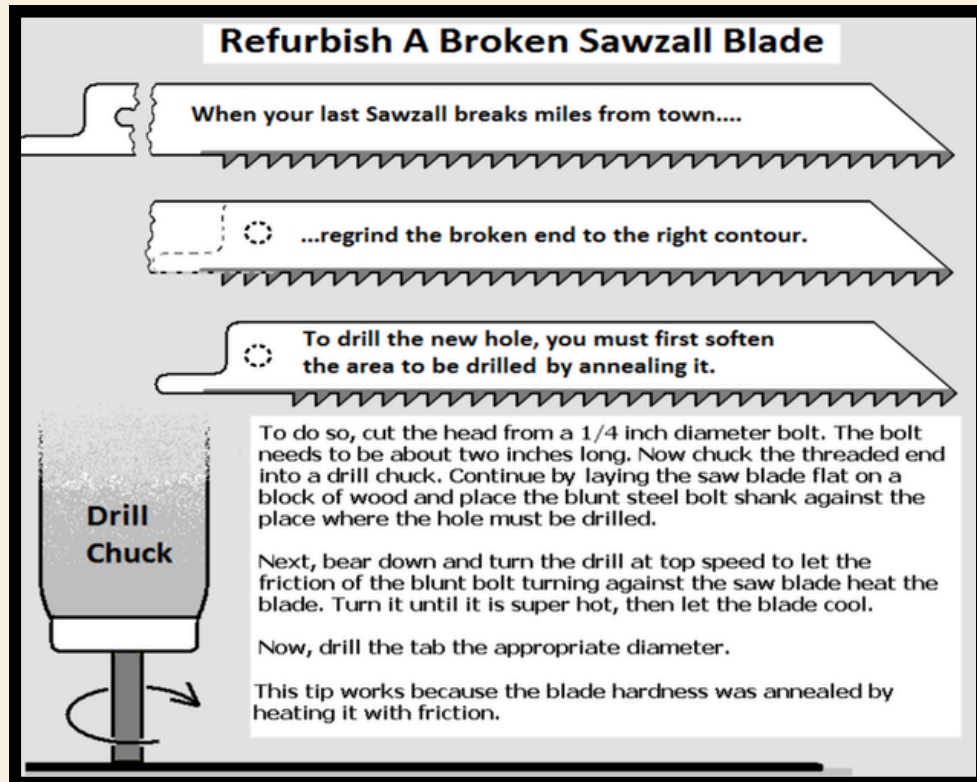

To anneal the area which is to be drilled, just put a drill bit backwards in the drill chuck. This blunt end can be turned against the blade with steady down pressure on the drill motor to create sufficient friction and heat.

Heating the area softens the metal and permits drilling a new hole.

6 - CUTTING A LARGER DIAMETER HOLE



There has been an earthquake.

In this emergency setting, a hole large enough for a heavy cable to pass through must be cut through a steel beam that must be moved to facilitate the moving of rubble that is trapping six children.

You find a drill motor and a one-inch diameter hole saw. However, the diameter of the steel cable end is $1\frac{1}{8}$ " , just a little larger than the available hole saw.

You notice a fire has started at the far end of the building where the children are awaiting rescue.

How to proceed ?

SOLUTION

Cut a Larger Hole With a Hole Saw

Any hole saw will make a larger hole than it was designed to cut.

If no larger saw can be obtained and you must make a larger hole, just squeeze the holesaw in a vice to make it oval instead of round.

This will make the "kerf" wider, and the hole will be larger.

After the emergency is over careful work with the vise will again make the saw near round.

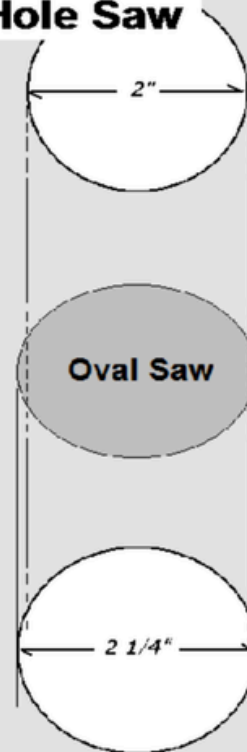

7- RUNNING OUT OF STARTING FLUID



It is a cold December day and there has been a strong earthquake and Tsunami. The only road for wheeled emergency response vehicles is blocked.

You have located a bulldozer above the high-water mark. The engine is reluctant to start in the cold. You do, however, find a beat up can of starting fluid in the toolbox.

Shaking the can reveals there is fluid within. Unfortunately, when you attempt to spray the fluid, there is no propellant pressure remaining in the can.

How to proceed ?

SOLUTION

Squeeze A Spray Can To Increase Internal Pressure

Ether Engine Starting Fluid

Penetrating Oil



Update: Ben Foster with Ben's Plumbing in Seattle assures me it works better to squirt air back in the can with the shop air system. Just hold an air nozzle against the can's nozzle and depress it while blowing air in with your shop blow nozzle.

8 - STARTING YOUR ENGINE WHEN THE BATTERY IS DEAD



It's a bitter cold day in Michigan. Returning from cutting firewood with your chainsaw, you decide to stop and ice fish for a while on the way home.

The fishing is good and you lose track of time. As the temperature drops below zero and the wind begins to howl, it is obviously time to drive home.

Returning to your truck, you find the battery is dead. It is getting late. No other traffic comes by and you have no jumper cables. There is nothing in the truck but the chainsaw, a gas can, and a few hand tools.

It's beginning to look like a long night.

How to proceed ?

SOLUTION

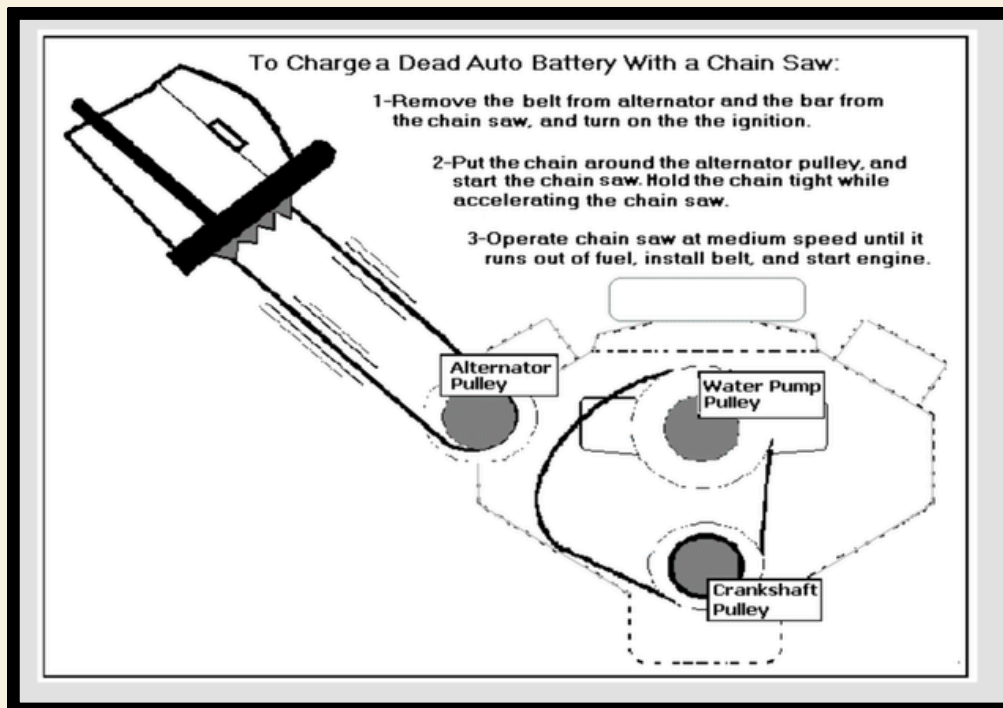

9 - A QUICK ENGINE QUALITY CHECK



After a wildfire passed through the day before, there is an urgent need to take supplies out to people on the front line of the firefighting effort.

The fire engulfed a local construction company's fleet of ten work-ready dump trucks. The fire missed, however, a lineup of four trucks waiting near the shop for repairs. The repair shop's staff is not available. It is up to you to select the best truck that will most likely complete the supply trip to the fire fighters.

You've checked fuel, oil, and coolant levels. The fan and alternator belts are in good condition, and the tires look good. The trucks all start and run. It is vital to use any means to choose the best truck!

How do you choose the truck with the best engine ?

SOLUTION

Quick And Rough Engine Check Strategy

This can help when in a time crunch, for example, when you need to buy a machine with limited inspection time.

Tap upward on the bottom of the oil pan (works only on sheet metal oil pans), and listen for the sound of bouncing trash (bearing metal, pieces of broken rods, etc.) in the oil pan. If anything does bounce in the pan, avoid this engine.

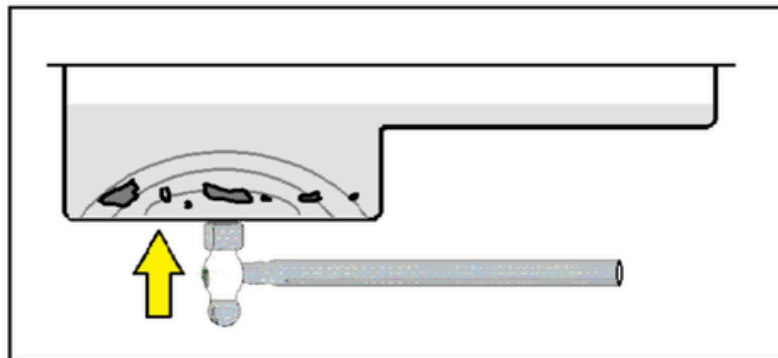

10 - EMERGENCY CUTTING OF STEEL



In this scenario, you need an acetylene torch to cut heavy steel members, to enable repairs to battlefield equipment.

The torch tip becomes so plugged that you cannot continue. The tip needs cleaning, but no tip cleaner is available.

How to proceed ?

SOLUTION

To clean a cutting torch in the field when a tip cleaner is not handy, put the torch against a block of wood and get it burning. When it starts burning, hit the oxygen and rub the tip of the torch back and forth against the wood a few times.

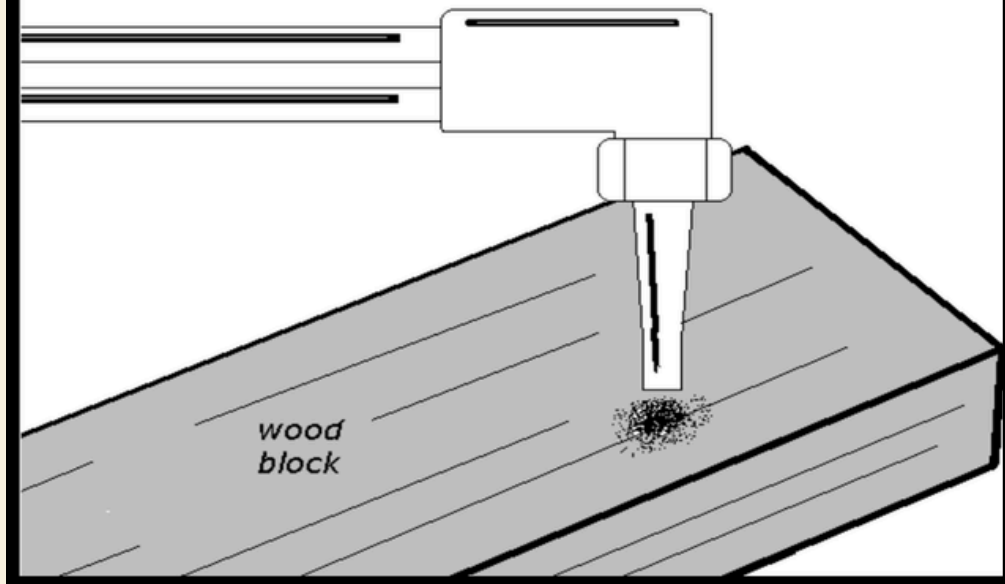

11 - NO WELDING ELECTRODES!



Again, you find yourself in a very remote and urgent setting, where welding is required to repair a vital piece of equipment.

Soon soon after starting to work, you run out of electrodes.

You are stuck.

How to proceed ?

SOLUTION

Make Flux Coated Welding Rod

To make low tensile strength flux coated electrode, proceed as follows:

- 1-Obtain wire coat hangers or other sources of steel wire.
- 2-Clean and straighten and cut to 14" lengths.
- 3-Heat the rod with a flame to burn off any plastic coating.

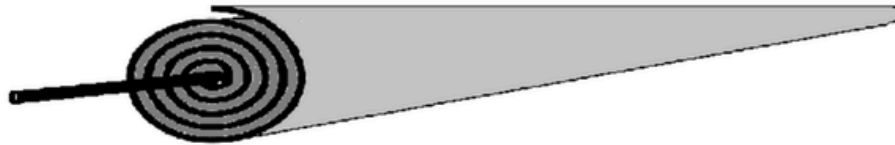

- 4-Cut strips of newspaper print to 13" X 6" in size.
- 5-Get liquid sodium silicate (a concrete sealing chemical).
- 6-Using gloves and eye protection, wet the newsprint with the sodium silicate.
- 7-Finally, wrap the wet newsprint tightly around the steel rods and bake at 220 degrees F to dry. Keep it dry until used.

12- WELDING STEEL



This situation is a variation on the previous scenario.
Still urgent. Very remote. You have plenty of electrodes...
But no welding power supply.

What to do?

SOLUTION

Welding Steel With Battery Power This works when an arc welder is not available

Control welding heat by:

1-Use more or less batteries as needed. Depending on the thickness of the steel to be welded, two, three, or more 12V batteries connected in series will work very well.

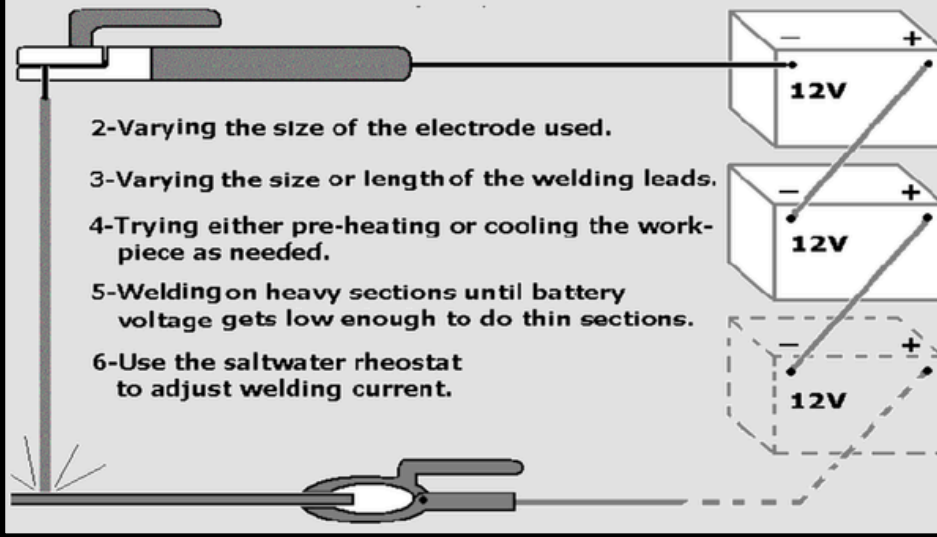

13 - STRIPPED CAMSHAFT COG BELT



Before evacuating four soldiers from a remote area, the engine in the small diesel-powered vehicle you are driving, suddenly quits running. It is the only vehicle available.

Checking it out, you find the camshaft drive belt has stripped, peeling off several of the rubber cogs that keep the camshaft and injection pump turning, in time, with the crankshaft.

There is a new belt available—1400 miles and three days away. Is your goose cooked? Not at all!

SOLUTION

Temporarily Salvage a Stripped Cam Drive Belt



Engine cam drive belts fail when the belt gets old and three or four cogs in one area of the belt "strip". What results is that the cam ceases to turn in time with the crankshaft and the engine will not run.

To get the engine to run again when a belt is not available, begin by removing the failed belt from the engine. Next, cut completely around the belt, right in the center of the belt. Make two belts of the one.

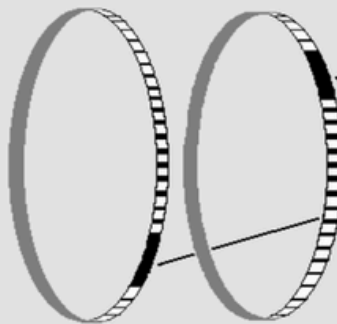

Now, finish by putting the first belt on. Then put on the second belt with the stripped cogs, several cogs away from each other's failed section, and both failed sections on the slackside of the crankshaft cogs. When it starts, don't turn it off until you get to where there is a new belt.

14 - FLAT TIRE/NO AIR COMPRESSOR



A vehicle took a bullet through the spare tire. It is this flat tire on a vital vehicle that is preventing a rescue operation.

You have some air hoses and a few tools, but no air compressor.

Is this the end?

SOLUTION

A diagram showing a blue air hose with a grey air fitting at the top left and a grey air fitting at the top right. The hose runs down the left side, across the bottom, and up the right side. There are two white rectangular boxes on the right side of the hose, one above the other, representing air fittings. The entire diagram is enclosed in a black border.

Use Equipment Tires As Emergency Air Supply

Emergency responders need compressed air for power tools and air-arc metal cutting after earthquakes.

Most heavy equipment and trucks have air brake systems to supply compressed air. Install air fittings in the system to allow an air hose to be connected to the vehicle.



Not only that, the tires on this equipment can be considered emergency air tanks. To take advantage of this fact, make up an emergency air hose.



**Disaster never rests.
Schedule your onsite seminar now.**

EMAIL: INFO@VIRTUALDIESEL.COM

PHONE: 1-360-477-3758

WEBSITE: WWW.VIRTUALDIESEL.COM

LINKEDIN: PILLAR CREEK EQUIPMENT